

DA 100B/150B Pad Cooling

Technical Info

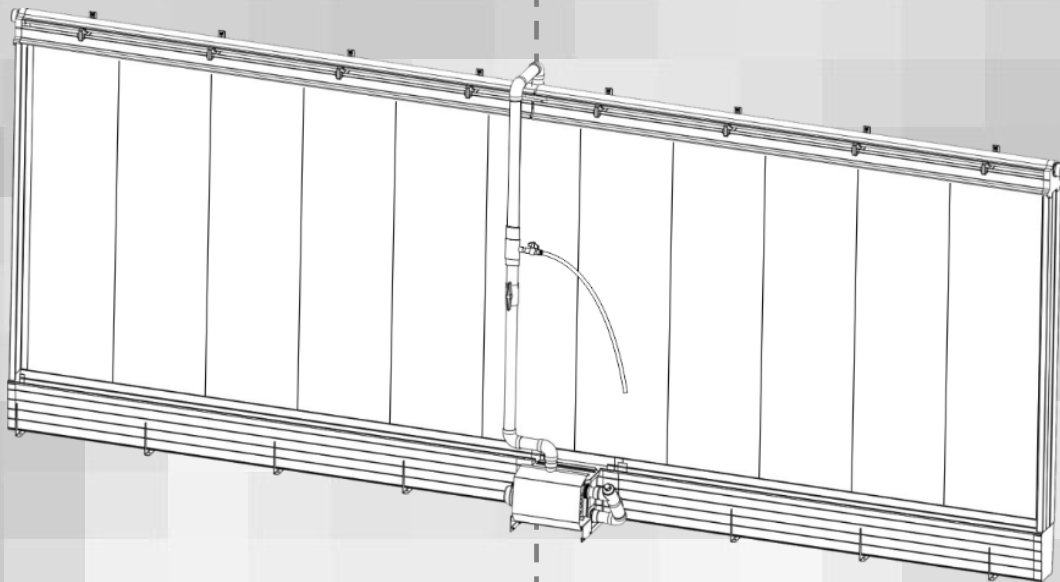

1 Product description

DA 100B/150B pad cooling is used in connection with SKOV Combi-Tunnel and Tunnel systems. The cooling takes place when the air is directed through the pads which are kept constantly moist by recirculating water. The air passes through these pads and is cooled when absorbing water vapour.

SKOV supplies a complete pad cooling system for cooling pads. The pad cooling system is flexible and can easily be adapted to the building in question.

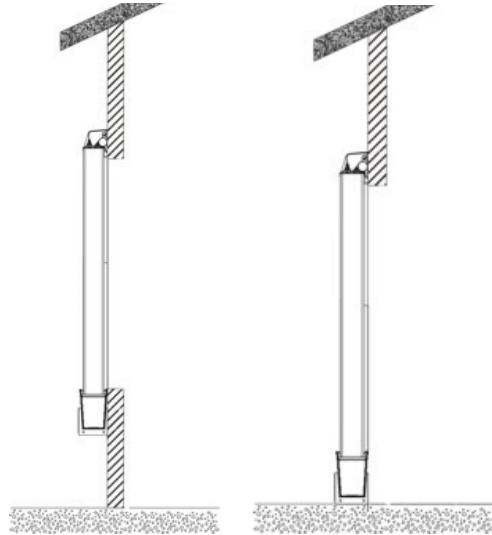

The pad cooling system can be mounted on the wall of the building or on the floor.

The total length of a pad cooling system can be up to 24 metres; max. height is 2.5 metres.

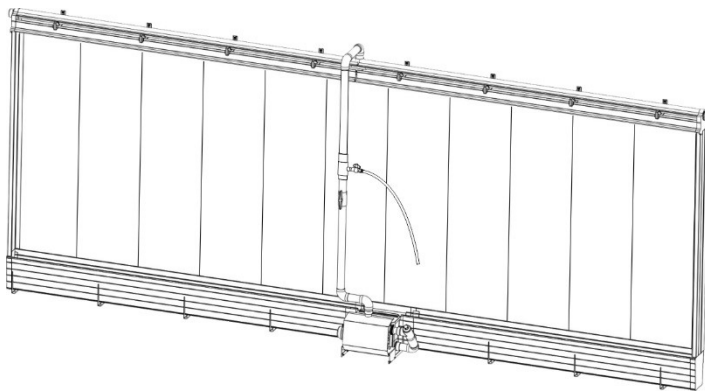

The supply unit with pump is mounted in the centre.

The water inlet to the water distribution pipe is mounted in the centre.

2 Product survey

2.1 DA 150B pad cooling

DA 150B pad cooling

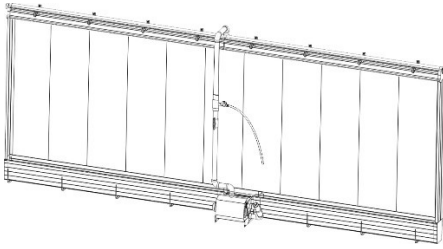

437773 DA 150B pad cool basic 6m 1x230V 50Hz

437774 DA 150B pad cool basic 6m 1x230V 60Hz

437759 DA 150B pad cool basic 6m 3X230/400V60Hz

Basic 6 m is a complete pad cooling system for 6 meter, i.e. supply unit, middle element and end kit.

Pads and glue must be ordered separately.

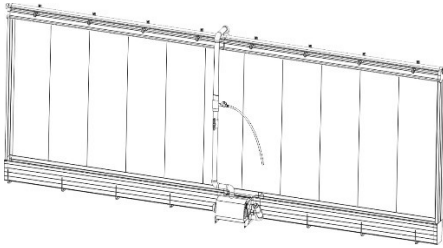

437783 DA 150B pad cool basic 6m ex pump

Basic 6 m is a pad cooling system for 6 meter, i.e. supply unit, middle element and end kit.

The supply unit is without pump.

Pads and glue must be ordered separately.

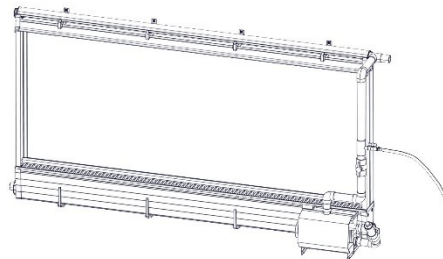

437778 DA 150B pad cool basic 3m 1x230V 50Hz

Complete pad cooling system for 3 meters, i.e. it contains:

- Supply unit with pump
- Middle element, end kit, non-return valve etc.

The performance of the pump is reduced and therefore is the max. length of pad cooling systems 3 meters.

Pads and glue must be ordered separately.

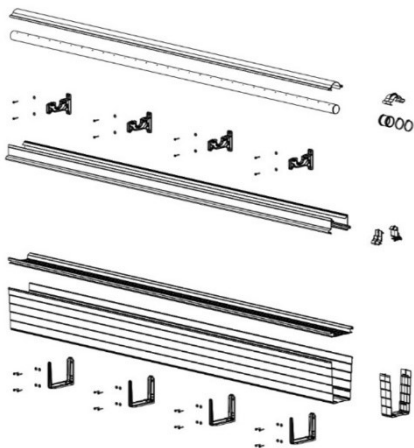

437828 DA 150B pad cool, extension 3 m

Extension 3 meter must be ordered if a pad cooling system longer than 6 meter is required.

The total length of a pad cooling system can be up to 24 metres.

Pads and glue must be ordered separately.

DA 150B pad cooling

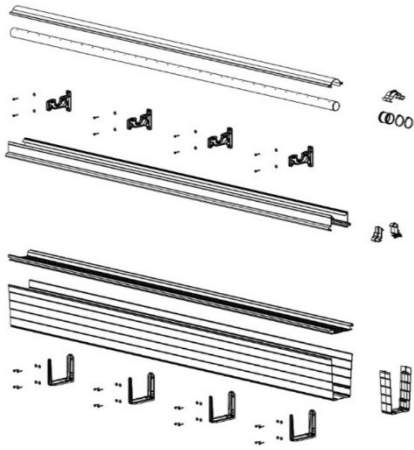

437824 DA 150B pad cool, extension 2x3 m

Extension 2x3 meter must be ordered if a pad cooling system longer than 6 meter is required.

The total length of a pad cooling system can be up to 24 metres.

Pads and glue must be ordered separately.

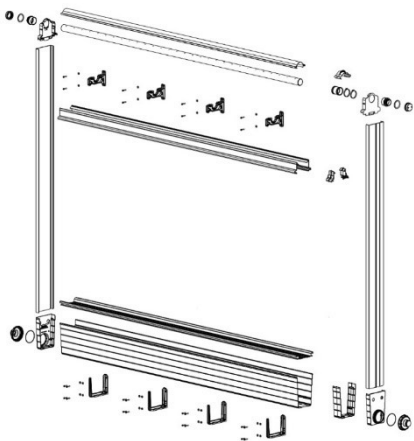

437709 DA 150B pad cool 3m corner connection

The connection system 3 m must be ordered if a pad cooling system around a corner is required or if a distance between the systems are required. Maks. 12 m pads after a corner can be connected.

Includes middle element, end kit and screw kit.

Order **437896** connection kit for connection of the system and possibly **437824** or **427828**.

The total length of a pad cooling system can be up to 24 metres.

Pads and glue must be ordered separately.

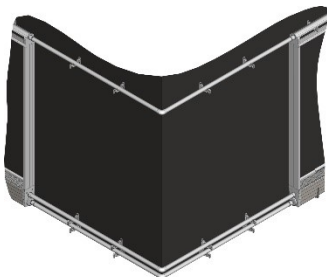

437895 DA 150B pad cool corner connect. kit V2

The connection kit includes 2500 mm PVC pipe, elbows, top brackets, transition pieces and various mounting parts. The connection system can be mounted max. 2500 mm from each side of the corner of the building.

Order one connection kit per corner.



351583 Tapp. screw 5x40 pan TX25 ZnNi spec.

When ordering the pad system, standard screws for mounting the pad cooling system are included.

If the pad cooling system is to be mounted in sandwich panels, it is recommended to order 9 pcs. tapping screws per running meters of pad cooling.

9 pcs. per running meters of pad cooling.



437269 Pad 150x600x1500 45/15 S

437270 Pad 150x600x1800 45/15 S

437271 Pad 150x600x2000 45/15 S

437269F Pad 150x600x1500 45/15 S

The SKOV standard pad.

F item numbers are produced in Asia which can be a logistic advantage.

DA 150B pad cooling



437256F Pad 150x600x1200 45/15 H

437251F Pad 150x600x1800 45/15 H

437250F Pad 150x600x2000 45/15 H

These pads are an alternative to SKOV's standard pads and are offered to customers specifically requesting Hutek pads.

F item numbers are produced in Asia which can be a logistic advantage.



437290 Pad 150x600x1500 45/15 G

437291 Pad 150x600x1800 45/15 G

437292 Pad 150x600x2000 45/15 G

These pads are an alternative to SKOV's standard pads and are offered to customers specifically requesting Gigola pads.

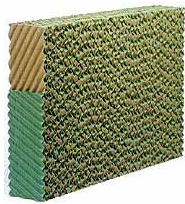

437313 Pad 150x600x1500 green stripe 45/15

437314 Pad 150x600x1800 green stripe 45/15

437315 Pad 150x600x2000 green stripe 45/15

437314F Pad 150x600x1800 green stripe 45/15

These pads are an alternative to SKOV's standard pads and are offered to customers specifically requesting Munters pads.

F item numbers are produced in Asia which can be a logistic advantage.



437287 Pad 150x600x1500 45/15 black coated S

437288 Pad 150x600x1800 45/15 black coated S

437289 Pad 150x600x2000 45/15 black coated S

437288F Pad 150x600x1800 45/15 black coated S

437289F Pad 150x600x2000 45/15 black coated S

437293F Pad 150x300x2000 45/15 black coated S

Black coated pads have a more robust surface and for this reason it easy-to-clean.

F item numbers are produced in Asia which can be a logistic advantage.



437284 Pad 150x600x1500 45/15 black coated

437285 Pad 150x600x1800 45/15 black coated

437286 Pad 150x600x2000 45/15 black coated

Black coated pads have a more robust surface and for this reason it easy-to-clean.

437279 Pad 150x600x2000 45/45 S

These pads are an alternative to SKOV's standard pads and are offered to customers specifically requesting a pad with a cross angle of 45/45, as the pressure loss for this pad type is 2-3 times higher.

DA 150B pad cooling



437262 Pad 150x600x1500 with light reduction

437261 Pad 150x600x1800 with light reduction

These pads are a light-reducing alternative to SKOV's standard pads. They refract the light twice and have a light reduction factor of 1,000,000. The pressure loss is 2-3 times higher compared to 45/15 pads.



437274 Pad PP150-3 150x600x1500

437275 Pad PP150-3 150x600x1800

437276 Pad PP150-3 150x600x2000

The plastic pad is very robust, UV-resistant, and easy to clean.



437928 DA 150B pump - reconstruction set

Use the reconstruction set if a DA 150B pump is to replace an existing DA 150 or DA 150A pump.



437584 DA 150B glue kit - max. 12m

Contains primer/cleaner, glue, and brush for gluing pipes and water gutter up to 12m.

2.2 DA 100B Pad Cooling

DA 100B Pad Cooling

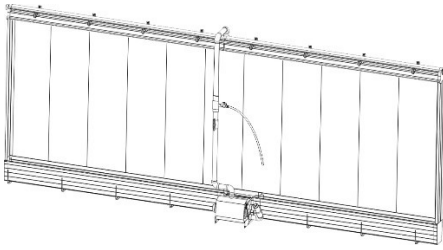

437776 DA 100B pad cool basic 6m 1x230V 50Hz

437766 DA 100B pad cool basic 6m 1x230V 60Hz

437758 DA 100B pad cool basic 6m 3X230/400V60Hz

Basic 6 m is a complete pad cooling system for 6 meter, i.e. supply unit, middle element and end kit.

Pads and glue must be ordered separately.

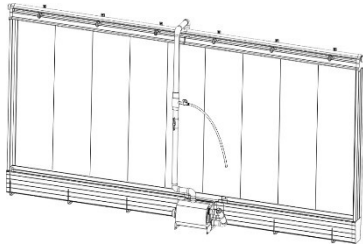

437717 DA 100B pad cool basic 3m 1x230V 50Hz

Basic 3 m is a complete pad cooling system for 3 meter, i.e. supply unit, middle element and end kit.

Pads and glue must be ordered separately.

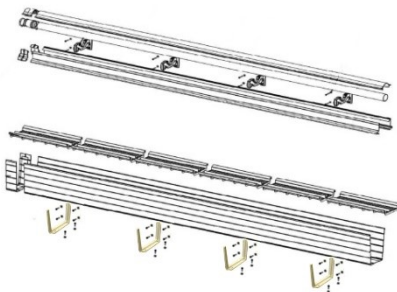

437829 DA 100B pad cool, extension 3 m

Extension 3 meter must be ordered if a pad cooling system longer than 6 meter is required.

The total length of a pad cooling system can be up to 24 metres.

Pads and glue must be ordered separately.

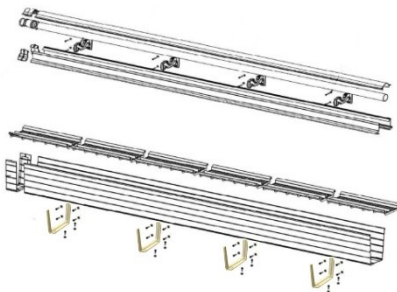

437826 DA 100B pad cool, extension 2x3 m

Extension 2x3 meter must be ordered if a pad cooling system longer than 6 meter is required.

The total length of a pad cooling system can be up to 24 metres.

Pads and glue must be ordered separately.

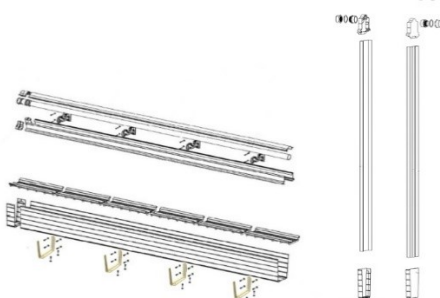

437710 DA 100B pad cool 3m corner connection

The connection system 3 m must be ordered if a pad cooling system around a corner is required or if a distance between the systems are required. Maks. 12 m pads after a corner can be connected.

Includes middle element, end kit and screw kit.

Order **437896** connection kit for connection of the system and possibly **437829** or **437826**.

The total length of a pad cooling system can be up to 24 metres.

Pads and glue must be ordered separately.

DA 100B Pad Cooling

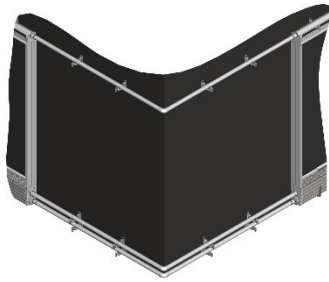

437896 DA 100B pad cool corner connect. kit V2

The connection kit includes 2500 mm PVC pipe, elbows, top brackets, transition pieces and various mounting parts. The connection system can be mounted max. 2500 mm from each side of the corner of the building.

Order one connection kit per corner.

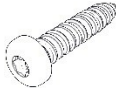

351583 Tapp. screw 5x40 pan TX25 ZnNi spec.

When ordering the pad system, standard screws for mounting the pad cooling system are included.

If the pad cooling system is to be mounted in sandwich panels, it is recommended to order 9 pcs. tapping screws per running meters of pad cooling.

9 pcs. per running meters of pad cooling.



437266 Pad 100x600x1500 45/15 S

437267 Pad 100x600x1800 45/15 S

437268 Pad 100x600x2000 45/15 S

437266F Pad 100x600x1500 45/15 S

437267F Pad 100x600x1800 45/15 S

437268F Pad 100x600x2000 45/15 S

The SKOV standard pad.

F item numbers are produced in Asia which can be a logistic advantage.



437263 Pad 100x600x1000 green stripe 45/15

437325 Pad 100x600x1800 green stripe 45/15

437326 Pad 100x600x2000 green stripe 45/15

437263F Pad 100x600x1000 green stripe 45/15

These pads are an alternative to SKOV's standard pads and are offered to customers specifically requesting Munters pads.

F item numbers are produced in Asia which can be a logistic advantage.



437281 Pad 100x600x1500 45/15 black coated

437282 Pad 100x600x1800 45/15 black coated

437283 Pad 100x600x2000 45/15 black coated

Black coated pads have a more robust surface and for this reason it easy-to-clean.



437928 DA 100B - reconstruction set

Use the reconstruction set if a DA 150B pump is to replace an existing DA 150 or DA 150A pump.

DA 100B Pad Cooling



437584 DA 100B glue kit - max. 12m

Contains primer/cleaner, glue, and brush for gluing pipes and water gutter up to 12m.

3 Technical data

DA 100B/150B pump				
Electric	437371	437370	437375	437374
Supply voltage [V]	1x230 (± 10 %)	1x230 (± 10 %)	1x230 (± 10 %)	3 x 230/400 (± 10 %)
Operational voltage [V AC]	207-253	207-253	220-240	220-240/380-420
Supply frequency [Hz]	50	60	50	60
Performance [m ³ /h]	18 (3 m)	18 (3 m)	9	18
Power input P ₁ [kW]	0.88	0.72	0.35	0.68
Power output P ₂ [kW]	0.45	0.45	0.18	0.45
Current [A]	3.9	3.5	1.95	1.9/1.1
Capacitor [µF]	25	25	6	-
Environment				
Max. ambient temperature [°C]	40	40	40	40
Max. liquid temperature [°C]	60	60	60	60
pH- range	6 – 9	6 – 9	6 - 9	6 - 9
Protection class	IP 55	IP 55	IP 55	IP 55
Class of insulation	F	F	B	B
Mechanics				
Suction/discharge [mm]	50	50	50	50
Weight [kg]	8.9	8.9	6.5	10.1

Total water supply to the system 2.5 m³/h (air speed 1.5 m/s).

Total water supply to the system 3.5 m³/h (air speed 2.0 m/s).

3.1 Load on the bracket

The load on one bottom bracket when the brackets are mounted at a distance of 0.75 metres	
Weight per bracket	60 kg
The load on one top bracket when the brackets are mounted at a distance of 0.75 metres	
Weight per bracket	6 kg

3.2 Water quality

Fresh water without bacteria and high contrations of both Hco₃ (bicarbonate) and Ca²⁺ (calcium) is required.

Pay attention if the concentration of Ca²⁺ (calcium) is higher than 50 mg/l.

